

AUTHOR: Jens Schoenfeld	LAST SAVED: 12.07.2010
CHECKED:	DATE:
ISSUED:	DATE:

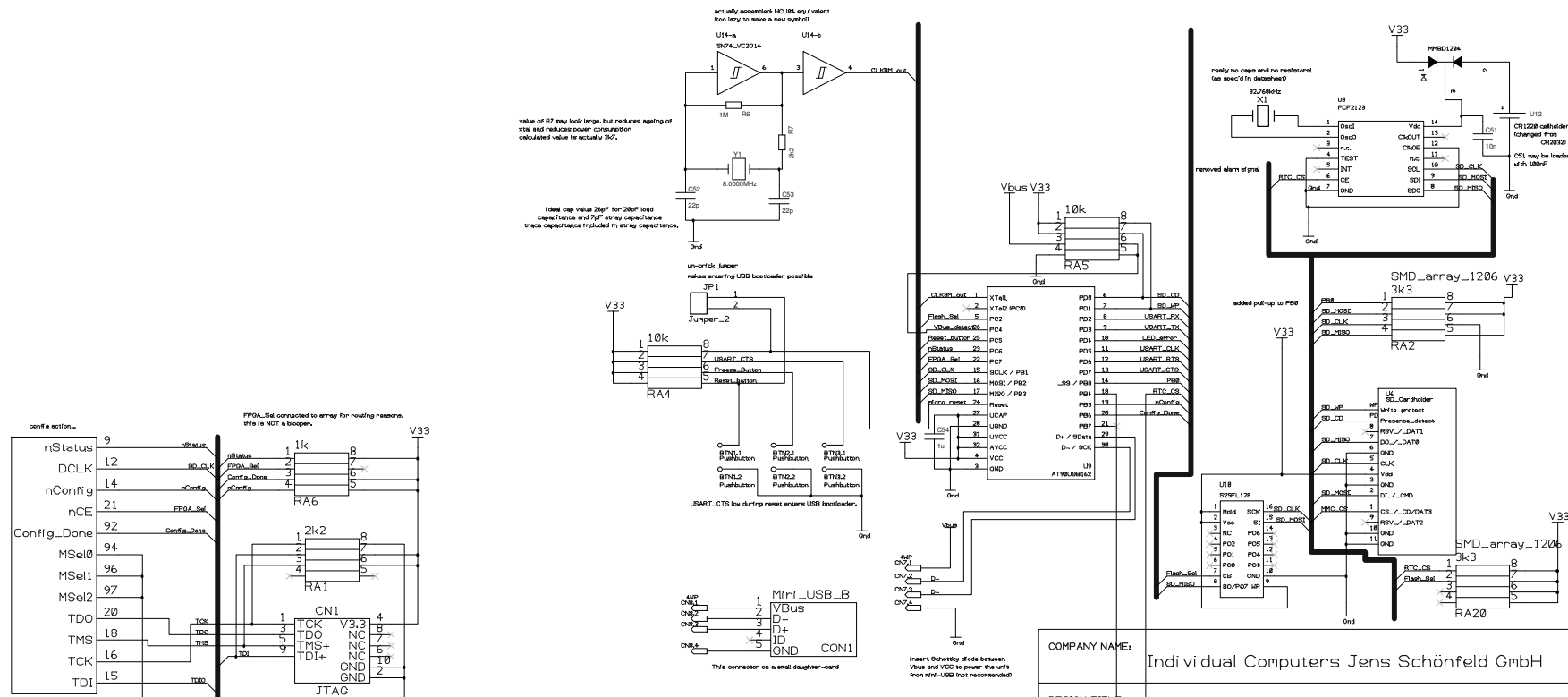

values of pull-up/down resistors may vary.

AUTHOR: Jens Schoenfeld	LAST SAVED: 12.07.2010
CHECKED:	DATE:
ISSUED:	DATE:

COMPANY NAME:	Individual Computers Jens Schönfeld GmbH		
DESIGN TITLE:	Chameleon - bright yellow!		
PAGE:	Microcontroller	DRAWING NO.:	REVISION:
SCALE:	SIZE: A3	SHEET 2 OF 3	

Dear reader,

page 3 of the Chameleon schematics is not open. It contains power setup, filters and analogue circuits. You will not need any of this for making your own FPGA core for Chameleon.

Kind regards,
Jens Schönfeld